

Parts No.	Description	Qty per Vehicel
-----------	-------------	-----------------



PMZ150-2-A-1Black	Front Leg Shield	1
PMZ150-2-A-1Red	Front Leg Shield	1
PMZ150-2-A-1Grey	Front Leg Shield	1
PMZ150-2-A-1Orange	Front Leg Shield	1
PMZ150-2-A-2	Front Turning Lights(Left)	1
PMZ150-2-A-3	Front Leg Shield Decorative Part (Left)	1
PMZ150-2-A-4	Headlight	1
PMZ150-2-A-5	Front panel (Small)	1
PMZ150-2-A-6	Driving lamp	1
PMZ150-2-A-7	Front Turning Lights(Right)	1
PMZ150-2-A-8	Front Leg Shield Decorative Part (Right)	1



Parts No.	Description	Qty per Vehicel
PMZ150-2-B-1	Rear Fender	1
PMZ150-2-B-2	Rear Wheel Fender	1
PMZ150-2-B-3	Number plate light	1
PMZ150-2-B-4	Rear Wheel Fender Bracket	1
PMZ150-2-B-5	Side Reflector	1 pair
PMZ150-2-B-6	Rear Reflector	1



Parts No.	Description	Qty per Vehicel
PMZ150-2-C-1	Footplate	1
PMZ150-2-C-2	Front Storage	1
PMZ150-2-C-3	Battery Cover	1
PMZ150-2-C-4	Front Head Cover, Hook	1
PMZ150-2-C-5	Round Usb	1 set
PMZ150-2-C-6	Front Storage Cover	1

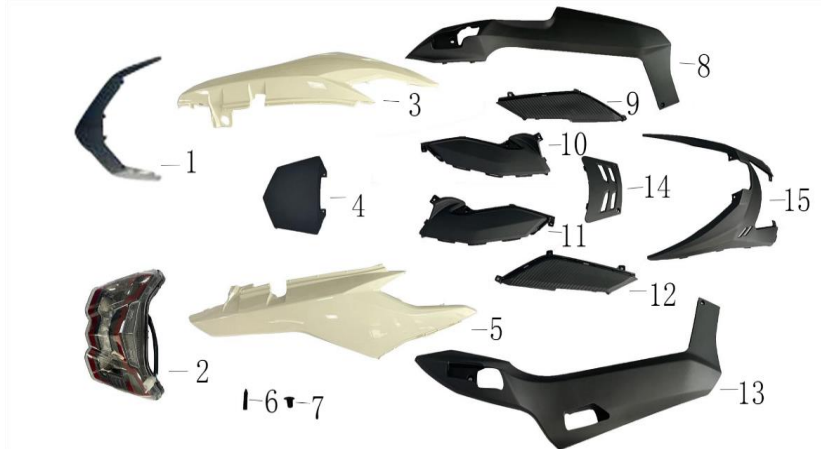

Parts No.	Description	Qty per Vehicel
PMZ150-2-D-1	Back center lower cover	1
PMZ150-2-D-2	Rear Light	1
PMZ150-2-D-3Black	Left Body Cover	1
PMZ150-2-D-3Red	Left Body Cover	1
PMZ150-2-D-3Grey	Left Body Cover	1
PMZ150-2-D-3range	Left Body Cover	1
PMZ150-2-D-4Black	Rear Cover	1
PMZ150-2-D-4Red	Rear Cover	1
PMZ150-2-D-4Grey	Rear Cover	1
PMZ150-2-D-4Orange	Rear Cover	1

PMZ150-2-D-5Black	Right Body Cover	1
PMZ150-2-D-5Red	Right Body Cover	1
PMZ150-2-D-5Grey	Right Body Cover	1
PMZ150-2-D-5Orange	Right Body Cover	1
PMZ150-2-D-6	Expansion Screws	6
PMZ150-2-D-7	Expansion Sleeve	6
PMZ150-2-D-8	Left Shield	1
PMZ150-2-D-9	Left rear guard	1
PMZ150-2-D-10	Front Left Body Cover	1
PMZ150-2-D-11	Front Right Body Cover	1
PMZ150-2-D-12	Right rear guard	1
PMZ150-2-D-13	Right Shield	1
PMZ150-2-D-14	Central Front Maintain Cover	1
PMZ150-2-D-15	Central Front Cover	1



Parts No.	Description	Qty per Vehicel
PMZ150-2-E-1	Seater	1
PMZ150-2-E-2	Box Luggage	1
PMZ150-2-E-3	Seater locker	1
PMZ150-2-E-4	Fuel tank overflow pad	1
PMZ150-2-E-5	Seat cushion hook welding combination	1
PMZ150-2-E-6	Rear Carrier Left pad	1
PMZ150-2-E-7	Rear Carrier Right pad	1
PMZ150-2-E-8	Rear grip cover plate	1
PMZ150-2-E-9	Rear Carrier	1

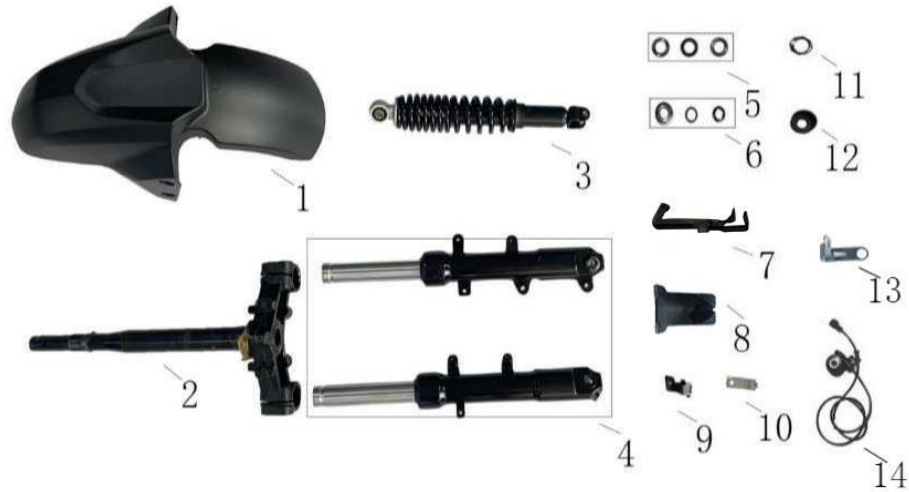

Parts No.	Description	Qty per Vehicel
PMZ150-2-F-1Black	Front Wheel fender	1
PMZ150-2-F-1Red	Front Wheel fender	1
PMZ150-2-F-1Grey	Front Wheel fender	1
PMZ150-2-F-1Orange	Front Wheel fender	1
PMZ150-2-F-2	Steering	1
PMZ150-2-F-3	Rear suspension	1
PMZ150-2-F-4	Front Suspension	1 pair
PMZ150-2-F-5	Bearing Upper	1
PMZ150-2-F-6	Bearing Under	1
PMZ150-2-F-7	Speedmeter Cable Clamper	1
PMZ150-2-F-8	Steering Cover	1
PMZ150-2-F-9	Disc Brake Tube Clamper	2
PMZ150-2-F-10	Induction wire bracket	1
PMZ150-2-F-11	Flange Lock Nut	1
PMZ150-2-F-12	Bearing cover	1
PMZ150-2-F-13	Speedmeter Cable Clamper	1
PMZ150-2-F-14	Electrical Speed Counter	1

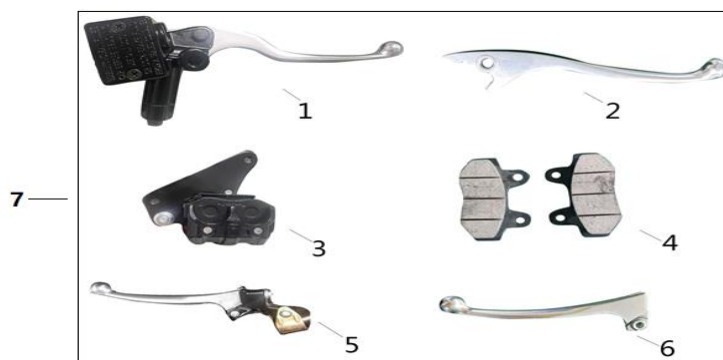

Parts No.	Description	Qty per Vehicle
PMZ150-2-G-7	Disc Brake Assy	1 set
PMZ150-2-G-1	Disc Brake Upper Pump	1
PMZ150-2-G-2	Brake Handle(Right)	1
PMZ150-2-G-3	Disc brake down pump	1
PMZ150-2-G-4	Disc Brake pads	1 pair
PMZ150-2-G-5	Left Brake Lever Assy	1
PMZ150-2-G-6	Holder Assy,Rear Brake Lever	1



Parts No.	Description	Qty per Vehicle
PMZ150-2-H-1	Dimmer switch	1
PMZ150-2-H-2	Horn switch	1
PMZ150-2-H-3	Front Turning Lights switch	1
PMZ150-2-H-4	Electric switch	1
PMZ150-2-H-5	Headlight switch	1
PMZ150-2-H-6Black	Handle down cover	1
PMZ150-2-H-6Red	Handle down cover	1
PMZ150-2-H-6Grey	Handle down cover	1
PMZ150-2-H-6Orange	Handle down cover	1

PMZ150-2-H-7Black	Handle upper cover	1
PMZ150-2-H-7Red	Handle upper cover	1
PMZ150-2-H-7Grey	Handle upper cover	1
PMZ150-2-H-7Orange	Handle upper cover	1
PMZ150-2-H-8	Windshield	1
PMZ150-2-H-9	Handle Rear Cover	1
PMZ150-2-H-10	Handle	1
PMZ150-2-H-11	Speedometer	1
PMZ150-2-H-12	Throttle base	1
PMZ150-2-H-13	Balancing	1 pair
PMZ150-2-H-14	Handle bar	1 pair
PMZ150-2-H-15	Mirror	1 pair
PMZ150-2-H-16	Throttle Cable	1
PMZ150-2-H-17	Rear Brake Cable	1
PMZ150-2-H-18	Mirror adapter	2
PMZ150-2-H-19	Speedometer Cable Clip	4
PMZ150-2-H-20Black	body kit	1 set
PMZ150-2-H-20Red	body kit	1 set
PMZ150-2-H-20Grey	body kit	1 set
PMZ150-2-H-20Orange	body kit	1 set

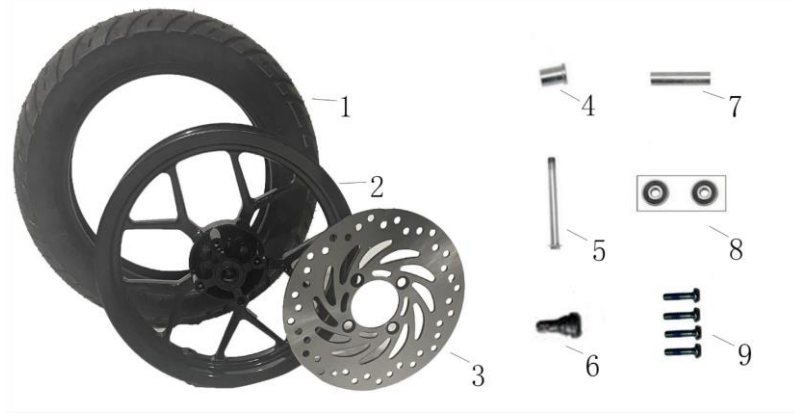

Parts No.	Description	Qty per Vehicle
PMZ150-2-I-1	Front Tire	1
PMZ150-2-I-2	Front Rim	1
PMZ150-2-I-3	Disc Brake Plate	1
PMZ150-2-I-4	Front Axle Bushing12*30	1
PMZ150-2-I-5	Axle 12*215	1
PMZ150-2-I-6	Front Air Valve	1
PMZ150-2-I-7	Front Wheel Inner Tube	1
PMZ150-2-I-8	Bearing 6201RS	2
PMZ150-2-I-9	Bolts	4



Parts No.	Description	Qty per Vehicel
PMZ150-2-J-1	Rear Tire	1
PMZ150-2-J-2	Rear Rim	1
PMZ150-2-J-3	Valve	1



Parts No.	Description	Qty per Vehicel
PMZ150-2-K-1	Clip7#	2
PMZ150-2-K-2	Clip8#	6
PMZ150-2-K-3	Square Sensor	1
PMZ150-2-K-4	Oil Switch	1
PMZ150-2-K-5	Fuel Cap	1
PMZ150-2-K-6	Filter	1
PMZ150-2-K-7	Fuel tank cap cover+Tie back	1
PMZ150-2-K-8	Air tube 3.7*7.6	1
PMZ150-2-K-9	Oil tube 4.5*8.5	1
PMZ150-2-K-10	Over flow pipe 11*7	1
PMZ150-2-K-11	Fuel Tank	1

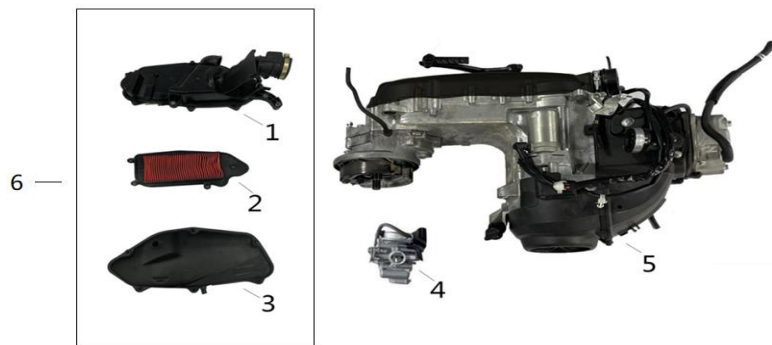

Parts No.	Description	Qty per Vehicel
PMZ150-2-L-6	Air Filter Assy	1
PMZ150-2-L-1	Air Filter Body	1
PMZ150-2-L-2	Air Filter Elements	1
PMZ150-2-L-3	Air Filter Outer Cover	1
PMZ150-2-L-4	Carburetor	1
PMZ150-2-L-5	Engine	1



Parts No.	Description	Qty per Vehicel
PMZ150-2-M-1	Muffler Gasket	1
PMZ150-2-M-2	Exhaust Muffler	1
PMZ150-2-M-3	Muffler Cover	1

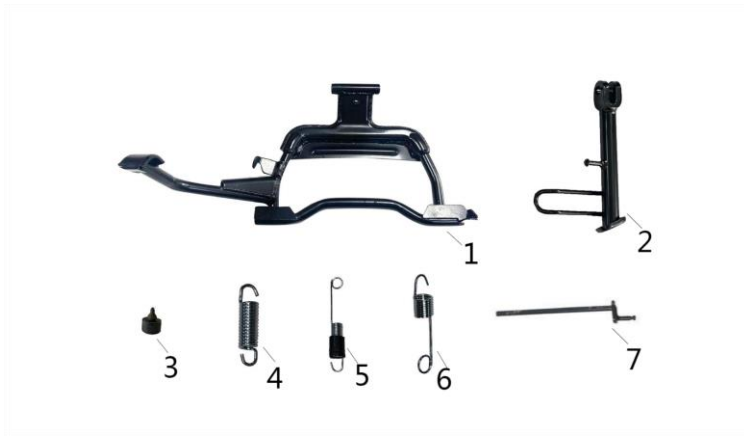

Parts No.	Description	Qty per Vehicel
PMZ150-2-N-1	Main Stand Assy	1
PMZ150-2-N-2	Side Stand Assy	1
PMZ150-2-N-3	Engine Hanger Rubber	1
PMZ150-2-N-4	Spring Of Main Stand	1
PMZ150-2-N-5	Side Stand Spring(Internal circlip)	1
PMZ150-2-N-6	Side Stand Spring(External circlip)	1
PMZ150-2-N-7	Pin, Starter Idle Gear	1



Parts No.	Description	Qty per Vehicel
PMZ150-2-O-1	Battery assy	1



Parts No.	Description	Qty per Vehicel
PMZ150-2-P-1	Wire Harness	1 set
PMZ150-2-P-2	Coil	1

PMZ150-2-P-3	Rectifier	1
PMZ150-2-P-4	Ignition/CDI	1
PMZ150-2-P-5	Horn	1
PMZ150-2-P-6	Relay	1
PMZ150-2-P-7	Flasher	1
PMZ150-2-P-8	Cable Clip	4
PMZ150-2-P-9	Ribbon	10
PMZ150-2-P-10	Relay bushing	1
PMZ150-2-P-11	Clamper	3

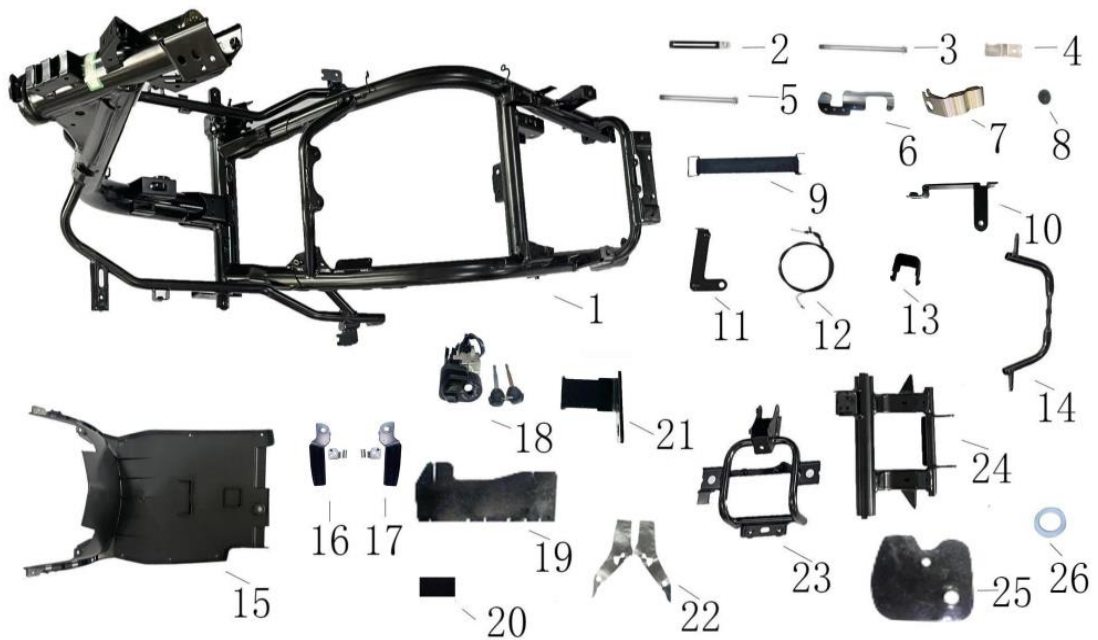

Parts No.	Description	Qty per Vehicle
PMZ150-2-Q-1	Frame	1
PMZ150-2-Q-2	Clamper With Screw Hole	7
PMZ150-2-Q-3	Axle 12*260	1
PMZ150-2-Q-4	Flasher fastening plate	1
PMZ150-2-Q-5	Axle 10*235	1
PMZ150-2-Q-6	Ignitioncoil Rack	1
PMZ150-2-Q-7	Throttle cable Clip	1
PMZ150-2-Q-8	License Holder Rubber	2
PMZ150-2-Q-9	Battery bandage	1
PMZ150-2-Q-10	Oil cup holder	1
PMZ150-2-Q-11	Electric door lock controller Rack	1
PMZ150-2-Q-12	Long Locker Cable	1
PMZ150-2-Q-13	Tieback cover	1
PMZ150-2-Q-14	Rear Fender Rack	1

PMZ150-2-Q-15	under cover	1
PMZ150-2-Q-16	Left Aluminum Padel	1
PMZ150-2-Q-17	Right Aluminum Padel	1
PMZ150-2-Q-18	Locker With Cable	1 set
PMZ150-2-Q-19	Water shield	1
PMZ150-2-Q-20	Switch locking pad	1
PMZ150-2-Q-21	Front Light Controller Rack	1
PMZ150-2-Q-22	Front Leg Shield shading paper	1 pair
PMZ150-2-Q-23	front bracket	1
PMZ150-2-Q-24	Engine Hanger Assy	1
PMZ150-2-Q-25	Oil pump waterproof pad	1
PMZ150-2-Q-26	White nylon flat gasket	2



Parts No.	Description	Qty per Vehicel
PMZ150-2-R-1	kill switch(optional)	1
PMZ150-2-R-2	press board,burglar alarm(optional)	
PMZ150-2-R-2-1	bag	1
PMZ150-2-R-2-2	Spark Plug Socket	1
PMZ150-2-R-2-3	Open end wrench	1
PMZ150-2-R-2-4	Screw Driver	1